

→ Check Valve

Technical Specification

Design Standard	ISO 15761/API 602/BS 5352/ASME B16.34
Testing Standard	API 598
Face to Face Standard	Manufacturer's Standard
Socket Weld Standard	ASME B16.11
Screwed End Standard	ASME B1.20.1
Butt Weld Standard	ASME B16.25
Flange End Standard	ASME B16.5

Material of Construction

08	NAME PLATE	STAINLESS STEEL	STAINLESS STEEL	STAINLESS STEEL	STAINLESS STEEL	STAINLESS STEEL
07	HEX BOLT (*)	ASTM A 193 GR. B7	ASTM A 193 GR. B8	ASTM A 193 GR. B8M	ASTM A 193 GR. B16	ASTM A 193 GR. B8M
06	CHECK PLATE	ASTM A 105	ASTM A 182 GR. F-304	ASTM A 182 GR. F-316	ASTM A 182 GR. F-22	ASTM A 182 GR. F-51
05	GASKET (*)	SS-316 SPW+GRAPHITE	SS-316 SPW + GRAPHITE	SS-316 SPW+GRAPHITE	SS-316 SPW+GRAPHITE	SS-316 SPW+GRAPHITE
04	SPRING	ASTM A 313 SS-304	ASTM A 313 SS-304	ASTM A 313 SS-316	ASTM A 313 SS-304	ASTM A 313 SS-316
03	PLUG	ASTM A 276 TYPE SS-410	ASTM A 276 TYPE SS-304	ASTM A 276 TYPE SS-316	ASTM A 276 TYPE SS-410	ASTM A 182 GR. F-51
02	SEAT RING	13% CR. INTEGRAL	ASTM A 182 GR. F-304 INTEGRAL	ASTM A 182 GR. F-316 INTEGRAL	13% CR. INTEGRAL	ASTM A 182 F-51 INTEGRAL
01	BODY	ASTM A 105	ASTM A 182 GR. F-304	ASTM A 182 GR. F-316	ASTM A 182 GR. F-22	ASTM A 182 GR. F-51
	DESCRIPTION	MATERIAL	MATERIAL	MATERIAL	MATERIAL	MATERIAL
		MOC A 105	MOC F-304	MOC F-316	MOC F-22	MOC F-51

*Marked Parts are not Applicable for Welded 2500#

Check Valve Cracking Pressure

Size	Piston Type	Y Pattern Piston Type
	Spring Loaded	Spring Loaded
15 mm	0.7 Bar	0.7 Bar
20 mm	0.7 Bar	0.7 Bar
25 mm	0.7 Bar	0.7 Bar
40 mm	0.7 Bar	0.7 Bar
50 mm	0.8 Bar	0.7 Bar

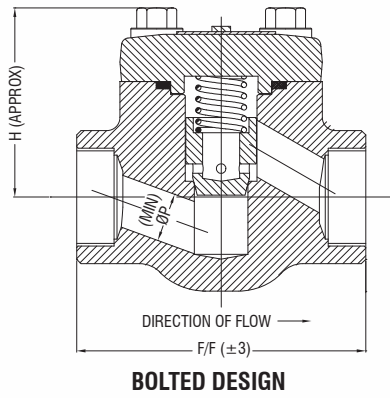

BOLTED DESIGN

Dimensions

800#	15mm (1/2")	20mm (3/4")	25mm (1")	32mm (1-1/4")	40mm (1-1/2")	50mm (2")
F/F (mm)	73	80	100	145	145	160
ØP (mm)	9.5	12.7	17.5	23.8	28.6	36.5
H (mm)	53	56	66	86	86	104
Approx. Weight (Kg)	1.0	1.2	2.1	4.8	4.7	7.7

1500#	15mm (1/2")	20mm (3/4")	25mm (1")	32mm (1-1/4")	40mm (1-1/2")	50mm (2")
F/F (mm)	80	100	145	145	160	172
ØP (mm)	8.5	9.5	14.5	20.5	25.5	27.5
H (mm)	56	66	86	86	104	127
Approx. Weight (Kg)	1.2	2	4.8	4.6	7.2	10.5

2500# Straight Type	15mm (1/2")	20mm (3/4")	25mm (1")	32mm (1-1/4")	40mm (1-1/2")	50mm (2")
F/F (mm)	100	145	160	172	172	-
ØP (mm)	7	12.5	15.5	21.5	26.5	-
H (mm)	66	86	104	127	127	-
Approx. Weight (Kg)	2	4.6	7.2	10.6	10.6	-

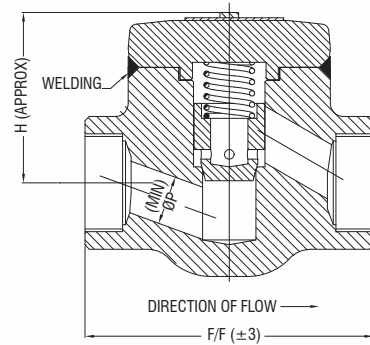

WELDED DESIGN

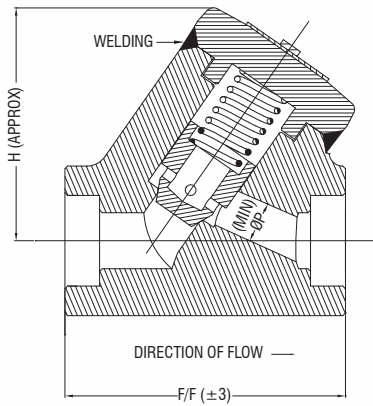

Y TYPE WELDED DESIGN

2500# Y Type	15mm (1/2")	20mm (3/4")	25mm (1")	32mm (1-1/4")	40mm (1-1/2")	50mm (2")
F/F (mm)	85	100	105	145	145	145
ØP (mm)	7	12.5	15.5	21.5	26.5	27
H (mm)	72	80	86	118	118	124
Approx. Weight (Kg)	1.3	2.1	2.8	7.1	7	9.5

150#	15mm (1/2")	20mm (3/4")	25mm (1")	32mm (1-1/4")	40mm (1-1/2")	50mm (2")
F/F (mm)	108	117	127	140	165	203
ØP (mm)	9.5	12.7	17.5	23.8	28.6	36.5
ØA (mm)	15.7	20.9	26.7	35	40.9	52.5
ØF (mm)	90	100	110	115	125	150
FT (mm)	9.6	11.2	12.7	14.3	15.9	17.5
ØRF (mm)	34.9	42.9	50.8	63.5	73	92.1
RFH (mm)	1.7	1.7	1.7	1.7	1.7	1.7
PCD (mm)	60.3	69.9	79.4	88.9	98.4	120.7
Approx. Weight (Kg)	1.7	1.9	3.6	3.8	7.4	11.6

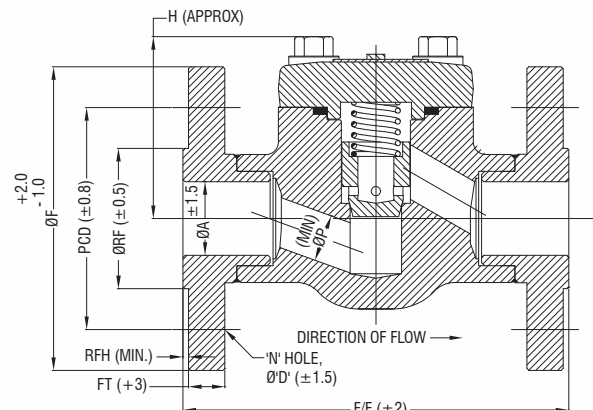

FLANGE END DESIGN

*Flange End Valve also Available in 300#, 600# & Above Class on Request.